

RubineTM

I T A L I A

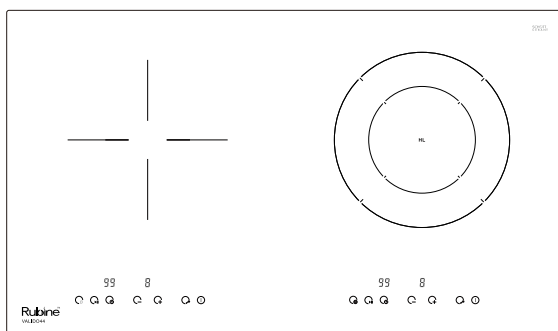
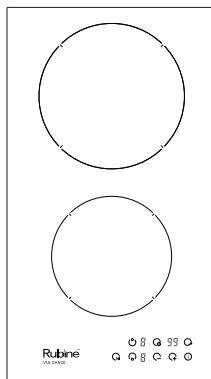
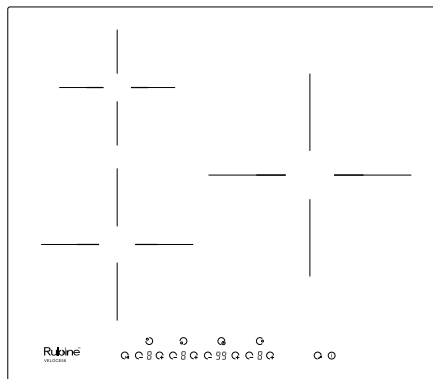

USER MANUAL

<p>MODEL</p>	<p><i>VULCAN series</i> <i>VELOCE series</i> <i>VALIDO series</i></p>
<p>SERIAL NO.</p>	

ELECTRIC HOB

CONTENTS:

Part 1. Safety Warnings

Part 2. Installation

Part 3. Operation Instructions

Part 4. Cleaning and Maintenance

Congratulations on the purchase of your new hob and thank you for choosing us!

Please read all the safety instructions carefully before use and keep this Manual for future reference.

Part 1. Safety Warnings

Safety Warnings

Your safety is important to us. Please read below information carefully before installing or using your Hob.

Installation

Electrical Shock Hazard

- Disconnect the appliance from the main electricity supply before carrying out any work or maintenance on it.
- Connection to good earth wiring system is essential and mandatory.
- Alterations to the domestic wiring system must only be made by a qualified electrician.
- Failure to follow this advice may result in electrical shock or death.

Panel Hazard

- Take care - panel edges are sharp.
- Failure to use cautiously could result in injury or cuts.

Important safety instructions

- Read these instructions carefully before installing or using this appliance.
- No combustible material or products should be placed on this appliance at any time.
- Please make this information available to the person responsible for installing the hob.
- In order to avoid a hazard, this appliance must be installed according to these instructions.
- This appliance is to be properly installed by a qualified person.
- This appliance should be connected to a circuit which incorporates an isolating switch providing full disconnection from the power supply.
- Failure to install the appliance correctly could void any warranty or liability claims.

Operation and maintenance

Electrical Shock Hazard

- Do not cook on a broken or cracked hob. If the hob surface should break or crack, switch the appliance off immediately at the main power supply (wall switch) and contact a qualified technician.
- Switch the hob off at the wall switch before cleaning or maintenance.
- Failure to follow this advice may result in electrical shock or death.

Health Hazard

- This appliance complies with electromagnetic safety standards.
- However, person with cardiac pacemakers or other electrical implants (such as insulin pumps) must consult with their doctor or implant manufacturer before using this appliance to make sure that their implants will not be affected by the electromagnetic field.
- Failure to follow this advice may result in death.

Hot Surface Hazard

- During use, accessible parts of this appliance will become hot enough to cause burns.
- Do not let your body, clothing or any item other than suitable cookware contact with the ceramic glass until the surface is cold.
- Beware: Metallic objects such as knives, forks, spoons and lids should not be placed on the hob surface since they can get hot.
- Keep away from children.
- Handles of saucepans may be hot to touch. Check saucepan handles do not overlap other cooking zones that are on. Keep handles out of reach of children.
- Failure to follow this advice could result in burns and scalds.

Blade Hazard

- The razor-sharp blade of a hob scraper is exposed when the safety cover is retracted. Use with extreme care and always store safely and out of reach of children.
- Failure to use caution could result in injury or cuts.

Important safety instructions

- Never leave the appliance unattended when in use. Over boiled causes smokes and greasy spillovers that may ignite.
- Never use your appliance as a work table or storage surface.
- Never leave any objects or utensils on the appliance.
- Do not place or leave any magnetisable objects (e.g. credit cards, memory cards) or electronic devices (e.g. computers, MP3 players) near the appliance, as they may be affected by its electromagnetic field.
- Never use your appliance for warming or heating the room.
- After use, always turn off the cooking zones as described in this manual. Do not rely on the pan detection feature to turn off the cooking zones when you remove the pans.
- Do not allow children to play with the appliance or sit, stand, or climb on it.
- Do not store items of interest to children in cabinets above the hob. Children climbing on the hob could be injured.
- Do not leave children alone or unattended in

the area where the appliance is in use.

- Children should have guardian to assist if they wish to use the appliance (we strongly recommend not to allow children to use the appliance for their safety). Besides, for disabled personnel, he/she must fully competent to use the appliances at its own risk & responsibility.
- Do not repair or replace any part of the appliance unless specifically recommended in the manual. All other servicing should be done by a qualified technician.
- Do not use steam cleaner to clean hob.
- Do not place or drop heavy objects on hob.
- Do not stand on your hob.
- Do not use pans with jagged edges or drag pans across the ceramic glass surface as this can scratch the glass.
- Do not use scourers or any other harsh abrasive cleaning agents to clean your hob, as these can scratch the ceramic glass.
- If the power supply cable is damaged, it must only be replaced by qualified technician.
- This appliance is intended to be used in household and similar applications such as:
 - staff kitchen areas in shops, offices and

other working environments; -farm houses;
-by clients in hotels, motels and other
residential type environments; -bed and
breakfast type environments.

- This appliance can be used by children aged from 8 years and above and persons with reduced physical, sensory or mental capabilities or lack of experience and knowledge if they have been given supervision or instruction concerning usage of the appliance in a safe way and understand the hazards involved. Children shall not play with the appliance. Cleaning and maintenance shall not be made by children without supervision.
- **WARNING:** Unattended cooking on a hob with fat or oil can be dangerous and may result in fire. NEVER try to extinguish a fire with water, but switch off the appliance and then cover flame e.g. with a lid or a fire blanket.

Part 2. Installation

Installation Instructions

The appliance must be installed and connected in accordance with current regulations.

After unpacking the appliance, ensure there is no visible damage. If it has been damaged during transit, **DO NOT USE**, contact where you buy immediately.

Selection of installation equipment

-Cut out the work surface according to the sizes shown in the drawing.

-For the purpose of installation and use, a minimum of 5 cm space shall be preserved around the hole.

-Be sure the thickness of the work surface is at least 30mm. Please select heat-resistant work surface material to avoid larger deformation caused by the heat radiation from the hotplate. As shown below (measure by unit: mm):

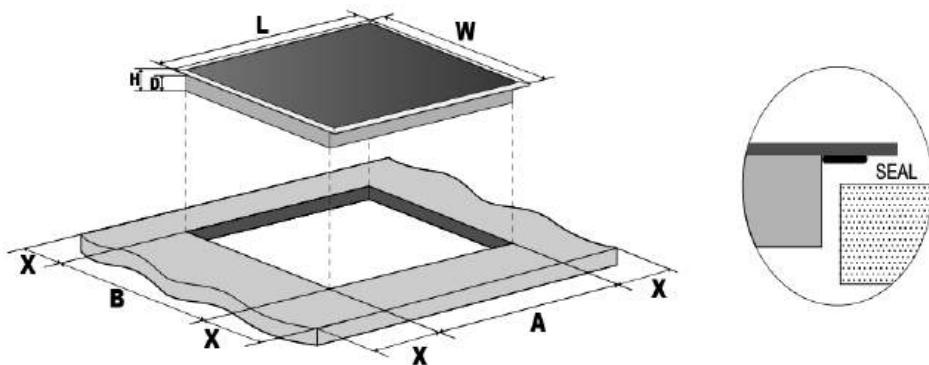

Model	L	W	H	D	A	B	X
RCE-VULCAN30-BL	288	520	52	48	265+5 -0	495+5 -0	50 min
RIH-VELOCE35-BL	288	520	56	52	265+5 -0	495+5 -0	50 min
RCE-VULCAN52-BL	590	520	52	48	555+5 -0	495+5 -0	50 min

RIH-VELOCE58-BL	590	520	56	52	555+5 -0	495+5 -0	50 min
RCE-VULCAN40-BL RIH-VELOCE44-BL RCH-VALIDO44-BL RCE-VULCAN44-BL	730	430	58	54	705+5 -0	405+5 -0	50 min
RCH-VALIDO53-BL	590	520	58	54	555+5 -0	495+5 -0	50 min

Installing the foam gasket

Before inserting the hob into the opening on the kitchen worktop, the supplied foam gasket (in a plastic bag) must be attached to the lower side of the ceramic glass.

**Do not install the hob without the foam gasket!
The gasket should be attached to the hob in the following method:**

- Remove the protective film from the gasket.
- Then attach the gasket to the lower side of the glass, next to the edge.
- The gasket must be attached along the entire length of the glass edge and should not overlap at the corners.
- When installing the gasket, make sure that the glass does not come into contact with any sharp objects.

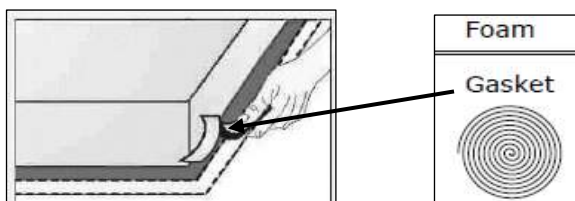

Under any circumstances, make sure the electric hob is well ventilated and the air inlet and outlet are not blocked. Ensure the electric hob is in good work state. As shown below:



Note: The safety distance between the hotplate and the cupboard above the hotplate should be at least 760mm.

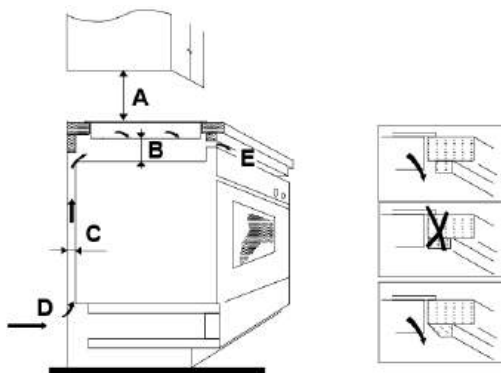

A(mm)	B(mm)	C(mm)	D	E
760mm	50mm minimal	20mm minimal	Air intake	Air exit 5mm

Before locating the fixing brackets

The unit should be placed on a stable, smooth surface (use the packaging). Do not apply force onto the controls protruding from the hob.

Easy Fit kits

There is one easy fit kits package for each hob, include fixing clips and screws (for ceramic hob total 2pcs clip and 2pcs screw, for induction hob total 4pcs clip and 4pcs screw). Find the easy fit kit package first.

Fix clips to hob: Insert the fixing clips into fixing holes reserved on 2 sides of housing, fix clip to housing with screw, then insert hob into cabinet/work surface.



Fix hob to cabinet: Insert the hob into the cabinet/work surface as below diagrams, the mounted clips on the sides can secure your hob sturdily.

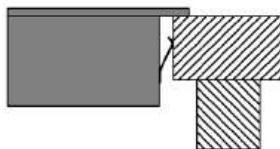

Connecting the hob to the mains power supply

The power supply should be connected in compliance with the relevant standard, or a single-pole circuit breaker. **The appliance has a large power rating and must be connected to electricity by a Qualified Electrician.**

Notes:

1. If the cable is damaged or needs replacing, this should be done by technician using the proper tools, so as to avoid any accidents.
2. If the appliance is being connected directly to the mains supply, an omni polar circuit breaker must be installed with a minimum gap of 3mm between the contacts.
3. The installer must ensure that the correct electrical connection has been made and that it complies with safety regulations.
4. The cable must not be bent or compressed.
5. The cable must be checked regularly and only replaced by qualified technician.

Cautions

1. **The hob must be installed by qualified personnel or technicians.** Please never conduct the operation by yourself.
2. The electric hob shall not be mounted to cooling equipment, dishwashers and rotary dryers.
3. The electric hob shall be installed such that better heat radiation can be ensured to enhance its reliability.
4. The wall and induced heating zone above the work surface shall withstand heat.
5. To avoid any damage, the in between layer and adhesive must be heat resistant.
6. Steam cleaner is not to be used for cleaning.
7. This electric hob can be connected only to a supply with system impedance not more than 0.427 ohm. In case necessary, please consult your supply authority for system impedance information.

The method of connections shown below.

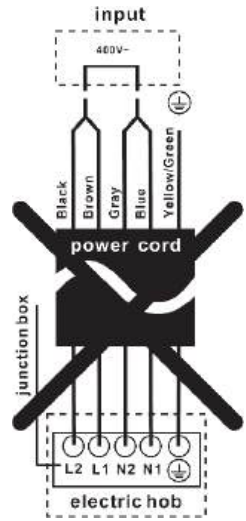
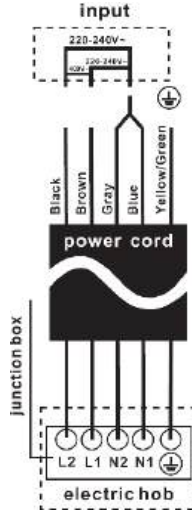
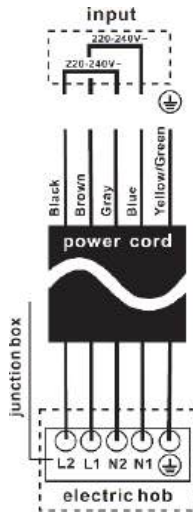
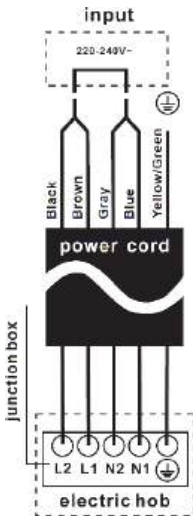
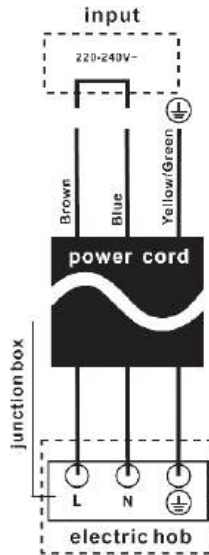

Part 3. Operation Instructions

Product Overview

Model: RCE-VULCAN30-BL

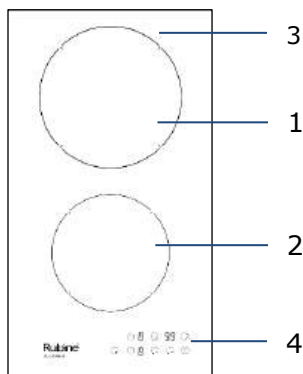

1. 1800W Cooking Zone
2. 1200W Cooking Zone
3. Glass plate
4. Control panel

Control Panel

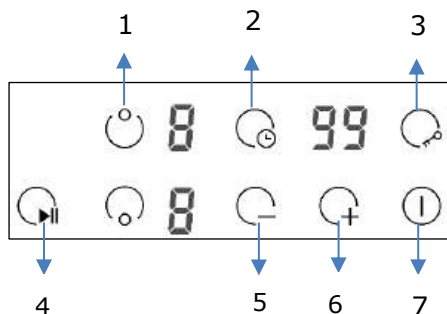

1. Cooking Zone selection button
2. Timer control button
3. Child Lock control button
4. Stop & Resume control button
5. Heating level/Timer "-" button
6. Heating level/Timer "+" button
7. ON/OFF button

Model: RCE-VULCAN40-BL

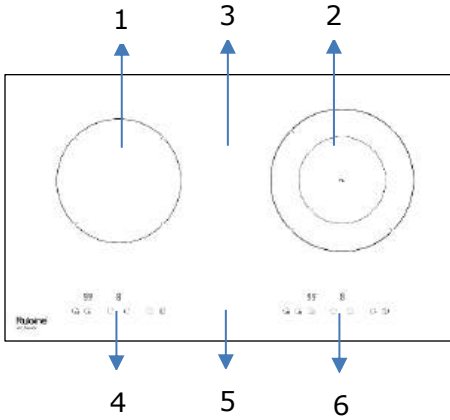

1. 1800W Ceramic Zone
2. 2200/1100W Ceramic Dual Zone
3. Ceramic Glass
4. Control panel of cooking zone#1
5. Timer control
6. Control panel of cooking zone#2

Control Panel

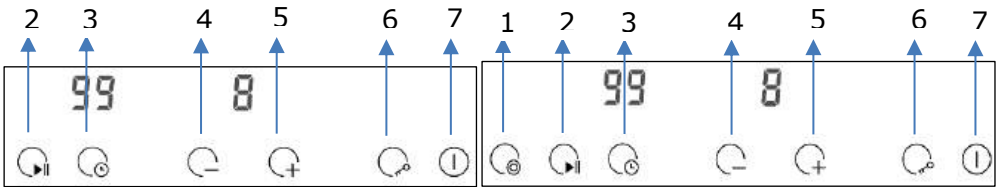

1. Extended zone control button
2. Stop & Resume control button
3. Timer control "-" button
4. Heating level/Timer "-" button
5. Heating level/Timer "+" button
6. Child Lock control button
7. ON/OFF button

Model: RIH-VELOCE44-BL

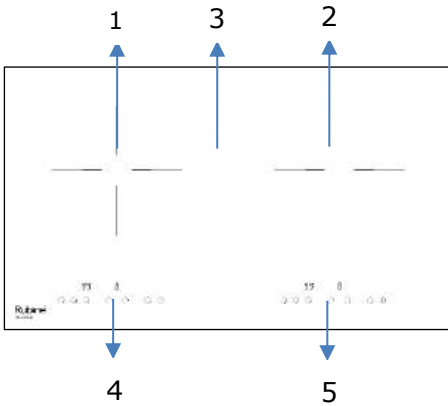

1. 2000W booster 2200W induction Zone
2. 2000W booster 2200W induction Zone
3. Ceramic Glass
4. Control panel of cooking zone#1
5. Control panel of cooking zone#2

Control Panel

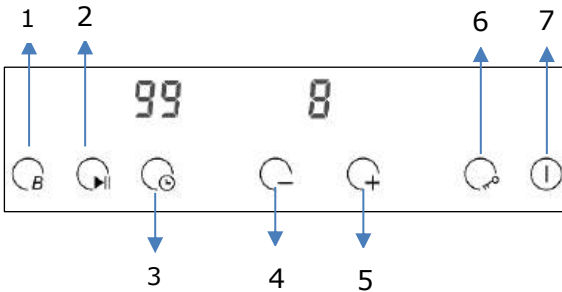

1. Booster function control button
2. Stop & Resume control button
3. Timer control button
4. Heating level/Timer "-" button
5. Heating level/Timer "+" button
6. Child Lock control button
7. ON/OFF button

Model: RIH-VELOCE58-BL

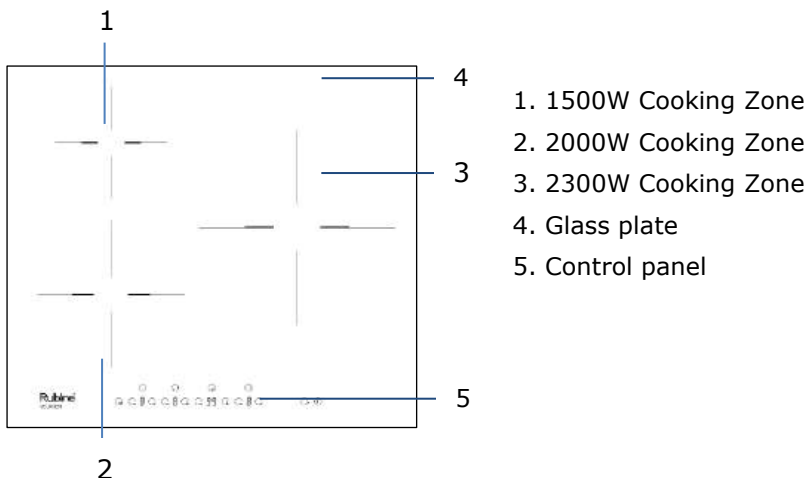

Control Panel

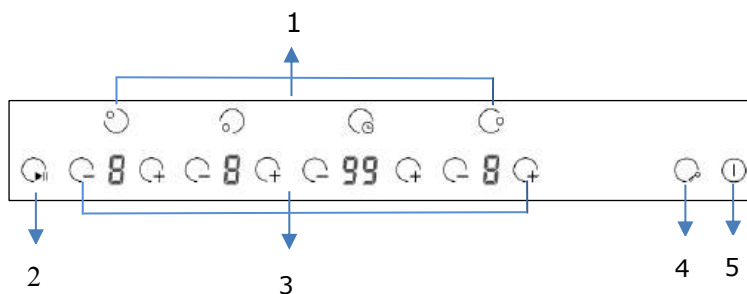

Model: RCH-VALIDO44-BL

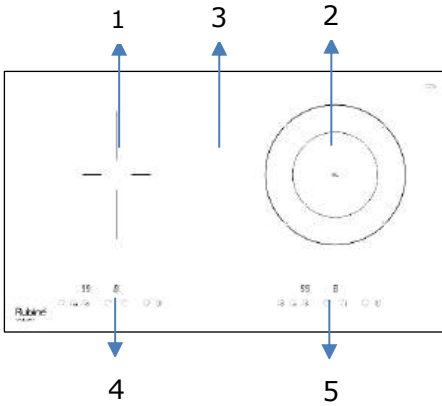

1. 2000W booster 2200W induction Zone
2. 2200/1000W Ceramic Dual Zone
3. Ceramic Glass
4. Control panel of cooking zone#1
5. Control panel of cooking zone#2

Control Panel

Induction Hob

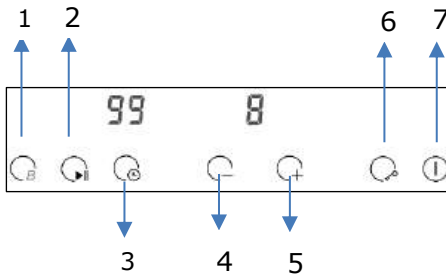

Ceramic Hob

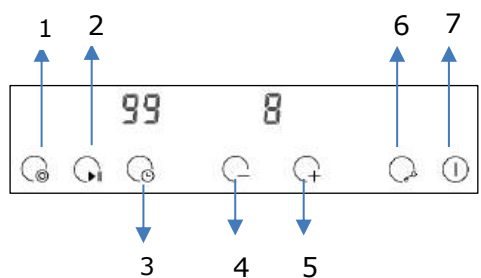

1. Booster/Extend zone control button
2. Stop & Resume control button
3. Timer control button
4. Heating level/Timer "-" button
5. Heating level/Timer "+" button
6. Child Lock control button
7. ON/OFF button

Model: RIH-VELOCE35-BL

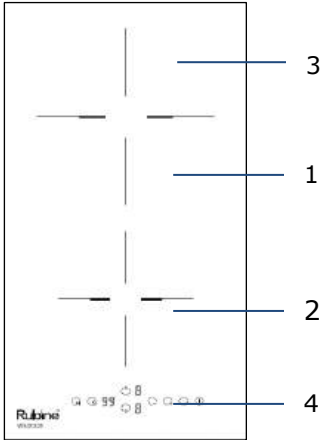

1. 2000W Cooking Zone
2. 1500W Cooking Zone
3. Glass plate
4. Control panel

Control Panel

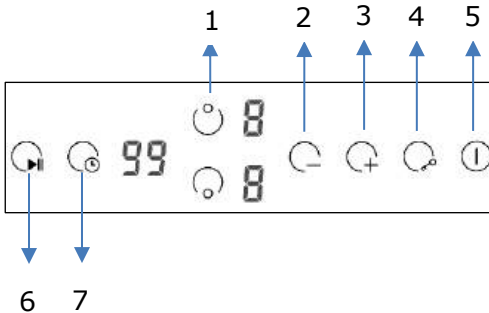

1. Cooking Zone selection button
2. Heating level/Timer "-" button
3. Heating level/Timer "+" button
4. Child Lock control button
5. ON/OFF button
6. Stop & Resume control button
7. Timer control button

Model: RCE-VULCAN44-BL

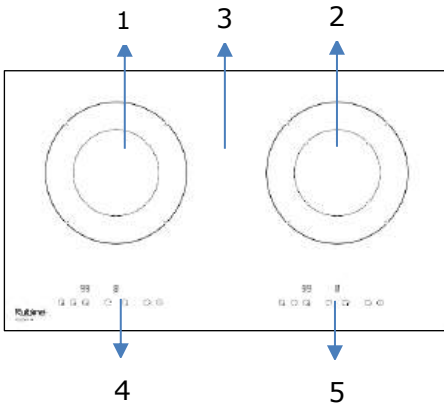

1. 2200/1100W Ceramic Dual Zone
2. 2200/1100W Ceramic Dual Zone
3. Ceramic Glass
4. Control panel of cooking zone#1
5. Control panel of cooking zone#2

Control Panel

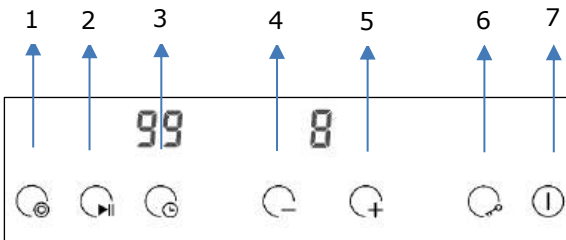

1. Extended zone control button
2. Stop & Resume control button
3. Timer control button
4. Heating level/Timer "-" button
5. Heating level/Timer "+" button
6. Child Lock control button
7. ON/OFF button

Model: RCE-VULCAN52-BL

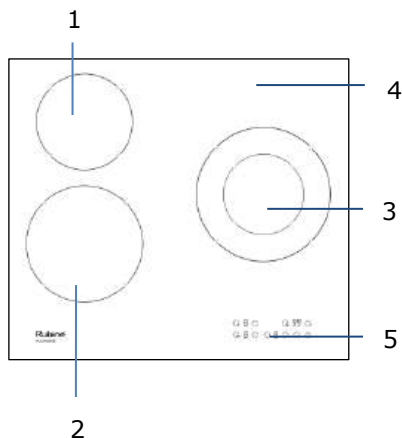

1. 1200W Cooking Zone
2. 1800W Cooking Zone
3. 2200W/1100W Dual Cooking Zone
4. Glass plate
5. Control panel

Control Panel

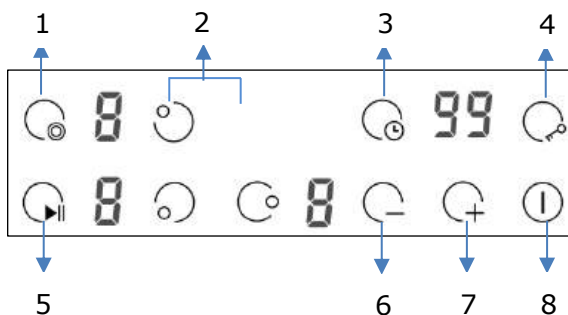

1. Extended zone control button
2. Cooking Zone selection button
3. Timer control button
4. Child Lock control button
5. Stop & Resume control button
6. Heating level/Timer "-" button
7. Heating level/Timer "+" button
8. ON/OFF button

Model: RCH-VALIDO53-BL

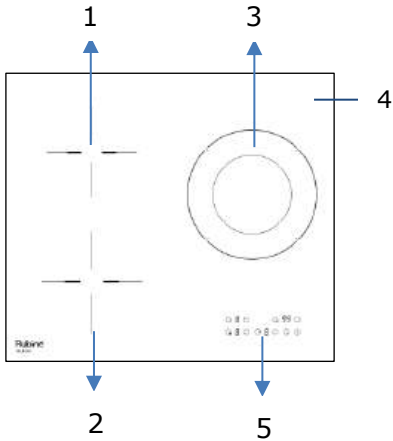

1. 1300W booster 1500W induction Zone
2. 1800W booster 2000W induction Zone
3. 2200W/1100W ceramic Zone
4. Ceramic Glass
5. Control panel

Control Panel

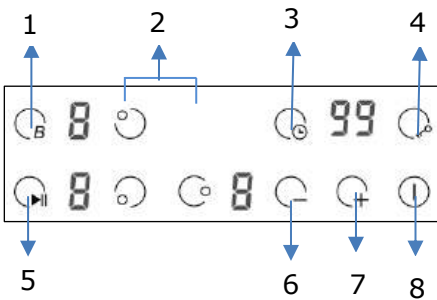

1. Booster/ Extended zone control button
2. Cooking Zone selection button
3. Child Lock control button
4. Stop & Resume control button
5. Timer control button
6. Heating level/Timer adjusting slider
7. ON/OFF button

Notes: Product diagrams in the manual for reference only, there might be slightly difference due to continually product improvements.

Before using your New Hob

- Read this guide, taking special note of the 'Safety Warnings' section.
- Remove any protective film that may still be on your new electric hob.

Using the Touch Controls

- The controls respond to touch, so you don't need to apply any pressure.
- Use your finger, not its tip.
- You will hear a beep each time a touch is registered.
- Make sure the controls are always clean, dry, and that there is no object (e.g. a utensil or a cloth) covering them. Even a thin film of water may make the controls difficult to operate.

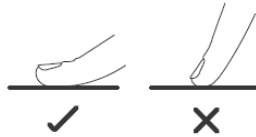

Choose the right Cookware

Do not use cookware with jagged edges or a curved base.



Make sure that the base of your pan is smooth, sits flat against the glass, and is the same size as the cooking zone. If you use smaller pot efficiency could be less than expected. Always centre your pan on the cooking zone.

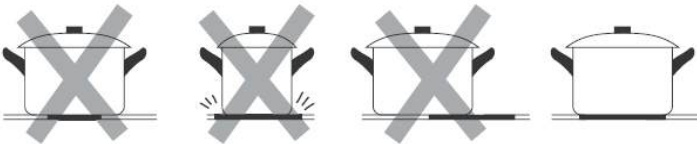

Always lift pans off the hob – do not slide, or they may scratch the glass.

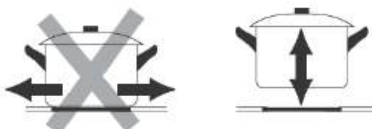

Notes: You can use any kind of pot or pan for Ceramic Hob.

Using your Hob

To start cooking

1. After the hob connected to electricity and power on.

Press and hold the ON/OFF  control button for about 3 seconds till you hear a "beep" to turn the hob on. Now the hob enters into Standby mode, all heat setting indicators and Timer setting indicators lit up.



2. Place a suitable pan on the cooking zone you wish to use.





- Make sure the bottom of the pan and the surface of the cooking zone are clean and dry.

3. Set heating level of cooking zone

3.1) **Touch control model for RCE-VULCAN30-BL/RIH-VELOCE58-BL/RIH-VELOCE35-BL/RCE-VULCAN52-BL/RCH-VALIDO53-BL**

Before adjust heating level, need to touch the heating zone selection control button to select and active the cooking zone you wish to use. The heat setting indicator of the selected zone will flash when activated, then you could adjust its heat level by below:

- Set heat setting by touching the  or  button.
- If press and hold either of the two buttons, the value will adjust down or up rapidly, from 0 to 9 in circle.

3.2) **Touch control model for RCE-VULCAN40-BL/RIH-VELOCE44-BL/RCH-VALIDO44-BL/RCE-VULCAN44-BL**, there is separate  and  heat level control button for each cooking zone for these models. Set heat setting by touching the  or  button for corresponding cooking zone.

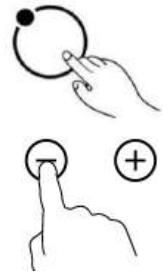
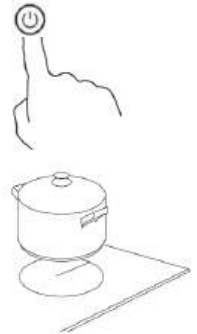

Notes:

1. After connect to electricity, and power on, the buzzer of hob beeps once, all indicators light up for 1 second.
2. When the hob in Standby mode, if there is no usage within 1 minute, the electric hob will auto turn off, with buzzer beeps once.
3. To turn on hob, press the ON/OFF control button and hold on for about 3 seconds; To turn it off, just need to press ON/OFF button again.
4. The power level can be adjusted from 0 to 9, default setting is level 5.
5. The heat setting indicator of the selected zone will flash when adjusting. After adjusting, the number flash for 5 seconds then stop flashing, then the setting is confirmed.

To turn off hob

1. You can turn the cooking zone off by adjust heat setting to level 0, which indicator shows "-".
2. You can also turn the whole hob off by touching the ON/OFF  control button.

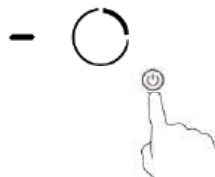

Note: If there is power cut off during cooking, all setting will be cancelled.

Note: The cooling fan of induction hob will remain on for about 1 minute after the hob turned off.

Child Lock Safety Control

- You can lock the controls to prevent unintended use (for example children accidentally turning the cooking zones on) by activate Child Lock function.
- When the controls are locked, except the ON/OFF control button and Child Lock control button, all other touch control buttons are disabled.



To lock the controls

Touch the Child Lock control button  once. The timer indicator will show "Lo", and Child Lock function be active.

To unlock the controls

1. Make sure the electric hob is turned on.
2. Touch and hold the Child Lock control button  for 3 seconds, the buzzer beeps once and "Lo" disappears in timer indicator, the Child Lock be inactive.
3. You can now start using your electric hob.



Under the child lock mode, all controls button be disable except the ON/OFF button  and child lock  button.

You can always turn the hob off with the ON/OFF  control in an emergency, but you need to unlock the hob in the next operation

Note: Under Child Lock function, if turn off the hob without deactivate the Child Lock function. When turn on the hob later, the Child Lock function will still valid.

Stop & Resume function

- **Make cooking easy!** When cooking, your doorbell rings, phone rings, or kid shouts from another door. Need to step out of kitchen? These means dinner could burn, or take longer time to ready if you switch everything off.
- The **Stop & Resume function** can turn off all zones. When you back, with one

more touching of the button , hob restarts where they were, to carry on cooking.

1. Active Stop & Resume function

To active **Stop & Resume** function, you can press the **Stop & Resume** function button once. Then all programmer setting be hold on and hob stop heating, all heat setting indicators show "P".

2. Inactive Stop & Resume function

To cancel **Stop & Resume** function, you can press the **Stop & Resume** function again, after come back. Then all programmer setting will return to what they were, Stop & Resume indicator "P" disappear from all indicators.



When **Stop & Resume** function active, all control buttons are disable except the ON/OFF and Stop & Resume button.

Note: The hob will auto turn off, if Stop & Resume function last more than 10 minutes.

Using the Timer

When the hob is turned on, you can use the timer in two different ways:

- You can use it as a minute reminder. In this case, the timer will not turn any cooking zone off when the set time is up.
- You can set it to turn either or more than one cooking zones off.
- You can set the minute minder/timer for up to 99 minutes.

Timer overview

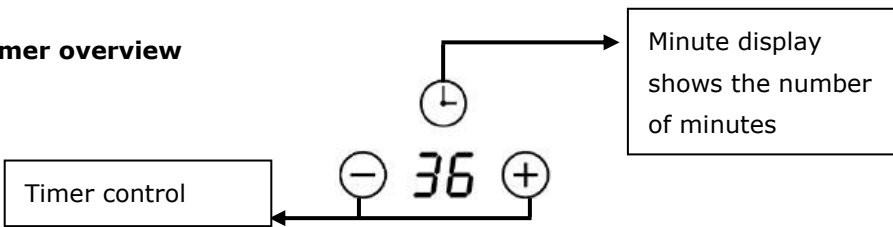

Using the Timer as a Minute Reminder



1)for model RCE-VULCAN30-BL/ RIH-VELOCE35-BL/
RCE-VULCAN52-BL/ RCH-VALIDO53-BL

If you have not selected any cooking zones

- 1.Touch the timer control button , the number in timer indicator will flash.



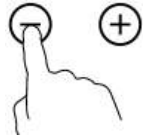

2. Then adjust Minute Minder setting follows below:

- Set timer setting by touching the  or  button.
- If press and hold either of the two buttons, the value will adjust down or up rapidly in circle.



2) for model RIH-VELOCE58-BL, set timer by touching the

 or  button of timer control.

Note: When the timer indicator flash, touch timer control button another time, can quickly confirm the timer setting.

Note: By continuous touch the timer control button, the slider works at below consequence: "Single Digit-Tens Digit -Confirm Setting-Single Digit-..."



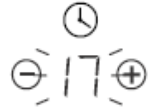

3. When the minute reminder is set, it will begin to count down immediately, the display will show the remaining time.

4. Buzzer will beep for 30 seconds and timer indicator shows "- -" when the setting time finished. Any touching of control buttons during it, would end up the buzzer beeps.



Setting the timer to turn cooking zone off

1) For model RIH-VELOCE58-BL

- Set timer by touching the  or  button of timer control.
- If press and hold either of the two buttons, the value will adjust down or up rapidly in circle.

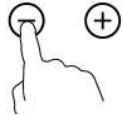



2) For other models

1. Touch the heating zone selection control button to select the cooking zone you wish to set timer for.



2. Touch the timer control button , the number in timer indicator flashing.

3. Then adjust Timer setting

- Set heat setting by touching the  or  button.
- If press and hold either of the two buttons, the value will adjust down or up rapidly in circle.

Note: When the timer indicator flash, touch timer control button another time, can quick confirm the timer setting.



Note: Continuous touch the timer control button, the slider works at below consequence: "Single Digit-Tens Digit-Confirm Setting -Single Digit-..."

4. When the timer is set, it will begin to count down immediately, the display will show the remaining time.

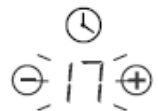

NOTE: The red dot next to power level indicator will illuminate for those zones be set with timer. You can check timer setting of different cooking zone which set with timer, by active this cooking zone.

NOTE: If more than one heating zone has timer setting, the timer indicator will show the lowest time. The red dot next to power level indicator will flash.

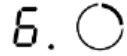

5. When cooking timer end, the corresponding cooking zone will be switch off automatically.

Note: The default setting of minute reminder and timer is 30 minutes.

Note: After adjusting, the setting in timer indicator will flash for 5 seconds and then stop flashing, then the setting confirmed.

Note: The minute reminder and timer can be use at the same time, timer indicator shows the lowest time setting. If it is set to minute reminder, the red dot next to timer indicator will flash. If it is set to timer setting, the red dot of corresponding cooking zone power level indicator will flash.

Note: Indicator shows timer setting of cooking zone. To check minute reminder setting, press the timer control button , the indicator will show minute reminder.

Residual Heat Warning

Beware of hot surfaces

When the hob has been operating for some time, there will be some residual heat. The letter " H "appears in power setting indicator to warn you to keep away from it.

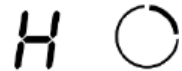

It can also be used as an energy saving function:

if you want to heat the pan further, use the zone that is still hot.

Auto Shutdown

Another safety feature of the hob is auto shutdown. This occurs whenever you forget to switch off a cooking zone. The default shutdown times as below table:

Power level	1	2	3	4	5	6	7	8	9
Default working timer (hour)	8	8	8	4	4	4	2	2	2

Over-heat Protection

A temperature sensor equipped can monitor the temperature inside the hob. Whenever an excessive temperature is monitored, the hob will auto stop operation.

Over-flow Protection

For your safety, the programme will auto shut off the power if boiling liquid or wet cloth over touch control panel. All control buttons became invalid except ON/OFF and Child Lock button, unless you wipe the touch control area dry.

Cooking Guidelines

Take care when frying as the oil and fat heat up quickly, especially if you are using Booster function. At extremely high temperature oil and fat will cause to ignite spontaneously and this presents a risk of fire.

Cooking Tips

- When food boils, reduce the power setting.
- Using a lid will reduce cooking times and save energy by retaining the heat.
- Minimize the amount of liquid or fat to reduce cooking time.
- Start cooking on a high setting and reduce the setting when the food has heated through.

Simmering, cooking rice

- Simmering occurs below boiling point, at around 85°C, when bubbles are just rising occasionally to the surface. It is the indicator to delicious soups and tender stews because flavour develop without overcooking the food. You should also cook egg-based and flour thickened sauces below boiling point.
- Some tasks, including cooking rice by the absorption method, may require a higher setting than the lowest setting to ensure the food is cooked properly within the recommended time.

Searing steak

To cook juicy flavoursome steaks:

1. Stand the meat at room temperature for about 20 minutes before cooking.
2. Heat up a heavy-based frying pan.
3. Brush both sides of the steak with oil. Drizzle a small amount of oil into the hot pan and then lower the meat onto the hot pan.
4. Turn the steak only once during cooking. The exact cooking time will depend on the thickness of the steak and how cooked you want it. Times may vary from about 2 – 8 minutes per side. Press the steak to gauge how cooked it is – the firmer it feels the more 'well done' it will be.

5. Leave the steak to rest on a warm plate for a few minutes to allow it to relax and become tender before serving.

For stir-frying

1. Choose a ceramic compatible flat-based wok or a large frying pan.
2. Have all the ingredients and equipment ready. Stir-frying should be quick. If cooking large quantities, cook the food in several smaller batches.
3. Preheat the pan briefly and add two tablespoons of oil.
4. Cook any meat first, put it aside and keep warm.
5. Stir-fry the vegetables. When they are hot but still crisp, turn the cooking zone to a lower setting, return the meat to the pan and add your sauce.
6. Stir the ingredients gently to make sure they are heated thoroughly.
7. Serve immediately.

Heat Settings

The settings below are guidelines only. The exact setting will depend on factors including your cookware and the amount you are cooking. Experiment with the hob to find the settings that best suit you.

Heat setting	Suitability
1 - 2	<ul style="list-style-type: none"> • delicate heating for small amounts of food • melting chocolate, butter, and foods that burn quickly • gentle simmering • slow heating
3 - 4	<ul style="list-style-type: none"> • reheating • rapid simmering • cooking rice
5 - 6	<ul style="list-style-type: none"> • pancakes
7 - 8	<ul style="list-style-type: none"> • sautéing • cooking pasta
9	<ul style="list-style-type: none"> • stir-frying • searing • bringing soup to the boil • boiling water

Part 4. Cleaning and Maintenance

Cleaning and Maintenance

Important: Before any maintenance or cleaning work is carried out, **DISCONNECT** the appliance from **ELECTRICITY** supply and ensure the appliances is completely cool.

Cleaning the Hob Surface

Clean spillages from the hob surface as soon as possible after use. Always ensure the surface is cool enough before cleaning.

Use a soft cloth or kitchen paper to clean the surface. If the spillage has dried on the surface, you may need to use specialist vitro-ceramic glass cleaner, which is available at most of the supermarkets.

Do not use other abrasive cleaners and/or wire wool ect., as it may scratch the ceramic glass surface.

Damage from Sugary Spills and Melted Plastic

Special care should be taken when removing hot substances **to avoid permanent damage of the glass surface.**

Sugary spillovers (such as jellies, fudge, candy, syrups) or melted plastics can cause pitting of the surface of your cooktop (**not covered by the warranty**) unless the spill is removed while still hot. Special care should be taken when removing hot substances.

Hints and Tips

What?	How?	Important!
<p>Everyday soiling on glass (fingerprints, marks, stains left by food or non-sugary spillovers on the glass)</p>	<ol style="list-style-type: none"> 1. Switch off the power supply. 2. Apply a vitro-ceramic glass cleaner while the glass is still warm (but not hot!) 3. Rinse and wipe dry with a clean cloth or paper towel. 	<ul style="list-style-type: none"> • When the hob is turned off, there will be no 'hot surface' indication but the cooking zone may still be hot! Take extreme care. • Heavy-duty scourers, some nylon scourers and harsh/abrasive cleaning agents may scratch the glass. Always read the label to check if your cleaner or scourer is suitable. • Never leave residue on the hob glass surface: the glass may become stained.
<p>Boil over, melts, and hot sugary spills on the glass</p>	<p>Remove these immediately with a fish slice, palette knife or razor blade scraper suitable for ceramic glass hob, but beware of hot cooking zone surfaces:</p> <ol style="list-style-type: none"> 1. Switch off the power supply. 2. Hold the blade or utensil at a 30° angle and scrape the soiling or spill to a cool area of the hob. 3. Clean the soiling or spill up with a dish cloth or paper towel. 4. Follow steps 2 to 3 for 'Everyday soiling on glass' above. 	<ul style="list-style-type: none"> • Remove stains left by melts and sugary food or spillovers as soon as possible. If left to cool on the glass, they may be difficult to remove or even permanently damage the glass surface. • Cut hazard: when the safety cover is retracted, the blade scraper is razor-sharp. Use with extreme care and always store safely and out of reach of children.
<p>Spillovers on the touch controls</p>	<ol style="list-style-type: none"> 1. Switch off the power supply. 2. Clean up the spill 3. Wipe the touch control area with a clean damp sponge or cloth. 4. Wipe the area completely dry with a paper towel. 5. Switch on the power supply to the hob. 	<ul style="list-style-type: none"> • The hob may beep and turn itself off, and the touch controls may not function while there is liquid on them. Make sure you wipe the touch control area dries before turning the hob back on.

Maintenance of the Hob

If there is something goes wrong for your hob, before contact customer service, please check the below:

1. There is no power to the appliance:

- Check whether there is a power cut of your hob;
- Check whether the appliance be connected to electricity properly;
- Has the timer setting elapsed;
- Whether it reaches the longest cooking time setting and auto shut off;
- Whether there is liquid boiling over touch control panel and overflow protection devices auto shut off;

2. The touch control panel buttons can't be active:

- Whether it's under "Child Lock", which there is "Lo" shows in timer displayer;
- Whether liquid/wet cloth over touch control panel active overflow protection;

3. After cooking there is "H" shows on display:

- This is normal. The hob is with Residual Heat Warning safety features. It will remain on until the surface is cool enough for touch.

4. After turn off, the fan of induction hob remains working for a while:

- This is normal, this is to help appliances completely cool down.

5. Some pans make crackling or clicking noises during use of induction hob:

- This is normal, it's the sound of induction coils during working, and for different construction of your cookware, the clicking might be slightly different.

6. The glass is being scratched:

- Check whether you use unsuitable cookware, like rough-edged cookware.
- Check whether unsuitable, abrasive scourer or cleaning products being used.

7. The heating element of ceramic hob turns on and off alternately when working:

- This is normal and natural feature for ceramic hob. Programmer of ceramic hob, together with the thermostat or thermocouple in heating element, could control the hob work at set power level and avoid overheat by heating element work on/off alternately.

-If working at highest power level, heating element will continue turn on for a certain time then on/off alternately.

-If working at other lower power level, heating element will on/off alternately at certain frequency since beginning based on power setting of the cooking zone.

Failure Inspection for induction hob

If an abnormality comes up, the induction hob will enter the protective state automatically and display corresponding protective codes:

Problem	Possible causes	What to do
E1/E2	Abnormal supply voltage	Please check whether power supply is normal, Power on after the power supply is normal.
E3	High temperature of the pan sensor	Check whether no liquid in pan, fill with liquid then restart.
E5	High temperature of the IGBT temperature sensor	Please restart after the induction hob cools down.

For all other error codes, switch off and call your service provider.

WARRANTY CARD

WARRANTY CONDITIONS

Subject to following Term & Conditions, this equipment is guaranteed against defective material & manufacturing defects by Fiamma Trading Sdn Bhd for a period of twelve (12) months from the original date of purchase. Fiamma Trading Sdn Bhd reserves the right to change the terms & conditions without prior notice.

Terms & Conditions:-

- 1) This warranty is valid provided that warranty card is completed with authorized dealer's stamp from the original date of purchase and in the territory of Malaysia only.
- 2) This warranty covers repair or, at the option of Fiamma Trading Sdn Bhd, replacement of any parts proven to be defective due to defective workmanship or material provided that the product was purchased from an authorized dealer of Fiamma Trading Sdn Bhd.
- 3) This warranty does not cover the damage resulting from:
 - (a) Any unauthorized disassembly, service repair, alteration or modification being carried out.
 - (b) Abnormal voltage or the use of generator and/or used not in accordance with the Operating Manual / User Manual.
 - (c) Misuse, abuse, negligence or accident howsoever caused.
 - (d) Normal wear or tear.
 - (e) Rough handling & transportation.
 - (f) Commercial / public use e.g. hotel, laundry, college, university, etc.
- 4) This warranty does not cover the following accessories:
 - (a) Burner Caps/Supports (b) Cast Iron Grib (c) Knobs (d) Body Work (e) Light Bulb (f) Charcoal / Filter (g) Cover (h) Glass Cover / Screen (i) Trays/Shelves (j) Hose
- 5) This warranty is considered null & void in the events if:
 - (a) Any item contained in this warranty card has been tempered with or altered in any way without the prior written consent of Fiamma Trading Sdn Bhd. Request for warranty services within the warranty period must be accompanied with this warranty card & original proof of purchase.
 - (b) Any time during the warranty period, any part / parts of this equipment is / are removed, altered, tempered with, adjusted, modified, dismantled, repaired or handled in any way whatsoever by any person / persons not authorized by us.
 - (c) The serial number of the product has been defaced or removed.
- 6) Warranty for WINE CHILLER compressor is (5) five years, gas refill and labor charges are excluded.
- 7) In the event of defects covered by this warranty arise during the warranty period, the purchaser shall be fully responsible for the delivery to our dedicated service centre (expect for the refrigerator, washing machine, ovens, cooker hood, gas cooker, dishwasher, dryer, built-in hob, freezer, water heater) for any work which shall need to be done pursuant to this warranty & subsequent collection of the equipment after the said work has been done.
- 8) This warranty is in lieu of any, and all other warranties expressed or implied warranty of merchantability or fitness for a particular purpose. Fiamma Trading Sdn Bhd assumes no liability for the breach of the warranty beyond correcting the breath in the manner described above. In no event shall Fiamma Trading Sdn Bhd be liable for consequential losses or damages, including loss of use or loss of profits resulting from the product.

FOR OFFICE USE

Model Name

Serial No
Barcode :

Customer's Name (In Block/Full Name)

Date of Purchase : [] [] DAY [] [] MTH [] [] [] [] YR

Customer's Address (Full Address) :

PostCode : [] [] [] [] State : _____

Customer's Tel No : (H) [] [] [] [] - [] [] [] [] [] [] (O) [] [] [] [] - [] [] [] [] [] []

Customer's Email : _____ (H/P) [] [] [] [] - [] [] [] [] [] []

Authorized dealer's stamp

Fiamma Trading Sdn. Bhd.

Customer Signature

Customer Care

AFTER-SALES SERVICE:

Exact Quality Sdn. Bhd.

Hotline: **03-6286 9000**

Email: **eqservice@fiamma.com.my**

OPERATION HOURS

08:30am - 06:00pm

(Monday - Friday, except public holiday)

Our Warranty

5 yrs
Warranty

FOR TEMPERED GLASS OF
GAS HOB ONLY

18 mths
Warranty

FOR ALL PRODUCTS
(EXCLUDING ACCESSORIES)

1 yr
Warranty
Extension

**1-year
Warranty
Extension
When Register
Online!**

Online Registration

1. Log on to www.rubine.com.my
2. Click on 'Support', followed by 'Products Warranty Registration' to proceed. You're required to sign up as a member.
3. Please fill up the necessary information, tick on the checkbox and click 'Next'.
4. You'll receive a notification of warranty registration confirmation via email.
5. Your warranty will be automatically extended for another 6 months upon registration online. Please keep your online warranty certificate for reference.



**Scan to go
registration site
directly!**

rubine.com.my



FIAMMA TRADING SDN BHD 330476-P (A member of Fiamma Holdings Berhad)

9-2, Wisma Fiamma, No.20, Jalan 7A/62A, Bandar Manjalara, 52200 Kuala Lumpur. Tel: 03-6279 8943